

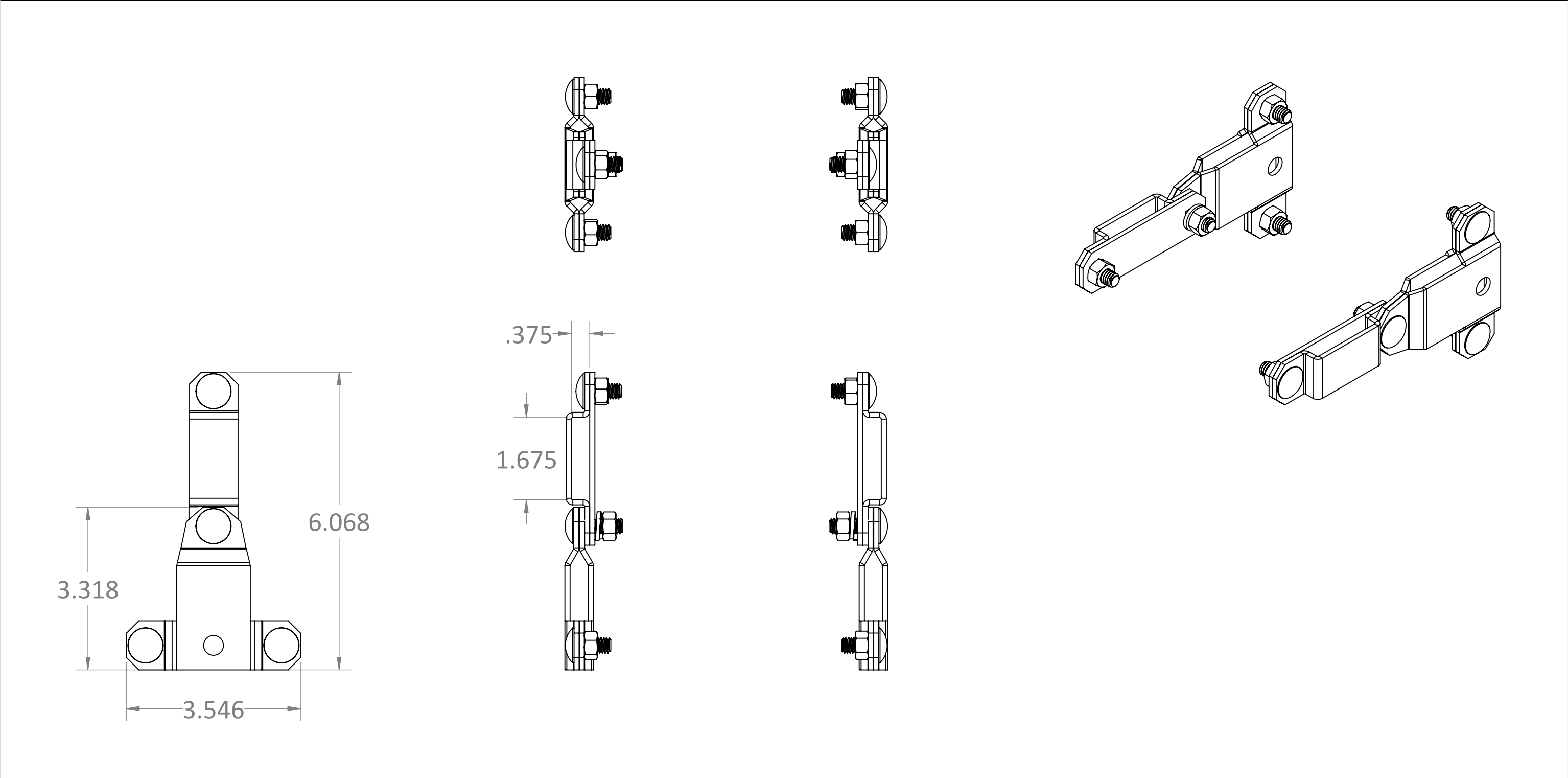

ITEM #	PART NUMBER	CONFIGURATION	DESCRIPTION	MATERIAL	QTY
1	AS-1016-01	X01	Vertical Swivel Kit Hardware Assembly		2



 <b>PROPRIETARY AND CONFIDENTIAL:</b> THE INFORMATION CONTAINED IN THIS DRAWING IS THE SOLE PROPERTY OF RXL. ANY REPRODUCTION IN PART OR AS A WHOLE WITHOUT THE WRITTEN PERMISSION OF RXL IS PROHIBITED.	SERIES/FAMILY NUMBER: <b>RXL-1016</b>		CONFIGURATION (SEE TABLE DETAILS/"X" DENOTES COLOR): <b>X01</b>		COMMENTS/FOLDER PATH: B:\RXL Inc\RXL Engineering - General\RXL\Section 1 - Cable Pathways\RXL-1016 Vertical Swivel Kit\		
	DESCRIPTION: <b>RXL-1016 Vertical Swivel Kit, 1.5" Stringer</b>					UNLESS OTHERWISE SPECIFIED: DIMENSIONS ARE IN INCHES TOLERANCES: ±0.03 FRACTIONAL: ±1/32 ANGULAR: ±1° TWO PLACE DECIMAL ±0.03 THREE PLACE DECIMAL ±0.030	
	REVISION <b>A</b>	DATE <b>8/4/2020</b>	REVISION DESCRIPTION: Initial		MATERIAL: FINISH: <b>PAINT</b>	SURFACE AREA: <b>121.47in.<sup>2</sup></b>	FULL PART NUMBER: <b>RXL-1016-X01</b> DRAWN BY: Jackson Chong DRAWN DATE: 8/4/2020 DO NOT SCALE DRAWING Scale: 1:4